

LSS Radar Series

—Low, Slow, and Small Target Detection Radar
with 3 KM, 5 KM, and 7 KM

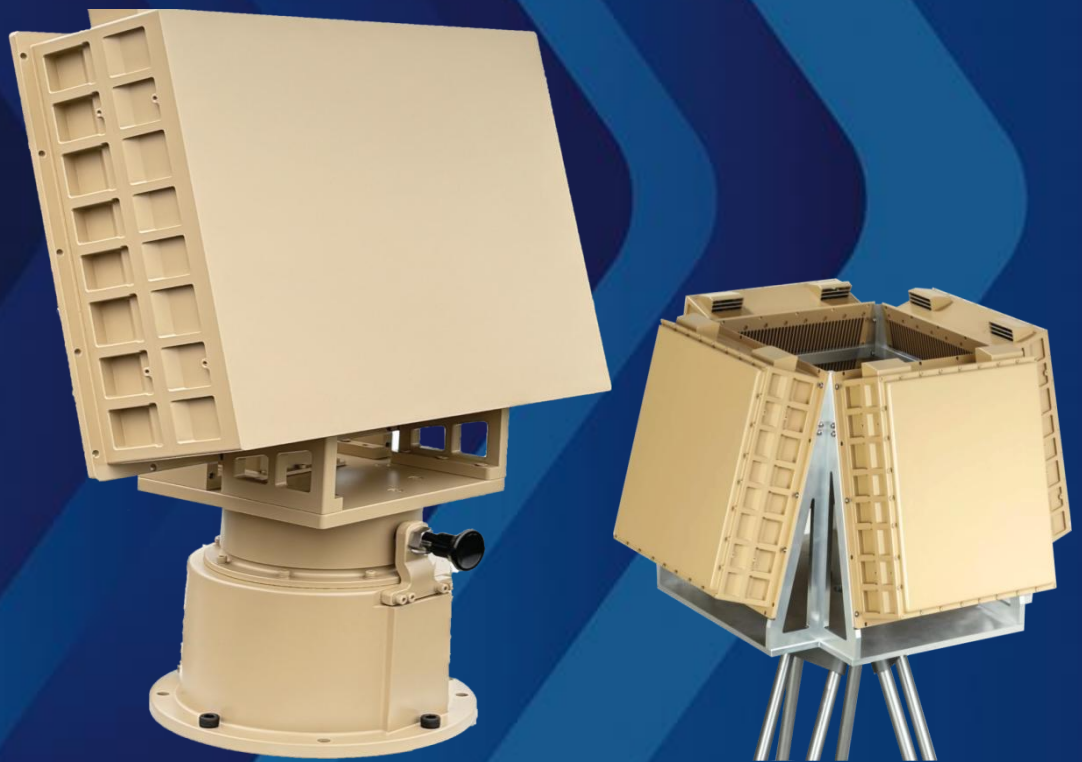



RM200 Radar

Product Characteristics

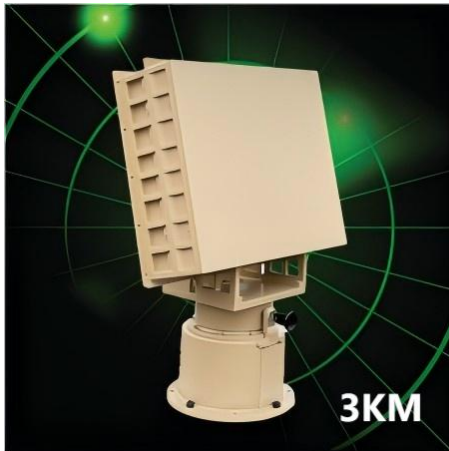

- Detection of low-speed small targets in complex background
- The interface has good compatibility and expandability, and can meet the needs of radar networking.
- Fast self-calibration and automatic fault diagnosis for radar equipment.
- With network communication interface.
- Multi-target tracking capability
- **Azimuth machine scan**
- **Two-dimensional phase scanning pulse Doppler system**
- **Three-coordinate radar**

Specifications

RM200 Radar	
Operating Mode	Azimuth mechanical scan, fully coherent, active 2D phased array
Operating Frequency	Ku-band
Detection Coverage	Azimuth: 360° @ mechanical scan; 90° @ electronic scan Elevation: 40° @ search; 60° @ track
Detection Range	≥3 km @ mechanical scan (search); ≥5 km @ electronic scan (search) (target RCS = 0.01 m ²)
Coverage Altitude	≥1 km
Target Speed Range	1 ~ 200 m/s
Data Update Rate	≤3 s @ search; ≤0.2 s @ track
Positioning Accuracy	Search mode: Azimuth ≤0.4°, Elevation ≤0.6°, Range ≤10 m Track mode: Azimuth ≤0.3°, Elevation ≤0.5°, Range ≤7.5 m
Target Handling Capacity	≥100 targets @ search; ≥4 targets @ track
Fault Detection Rate	≥90%
Power Supply	DC / 24V
Control Interface	Gigabit Ethernet
Power Consumption	≤360W
Physical Dimensions	Antenna Panel: 339 mm × 347 mm × 120 mm Rotator Unit: Φ216 mm × 173 mm (W × H)



RM300 Radar

Product Characteristics



- Detection of low-speed small targets in complex background.
- The interface has good compatibility and expandability, and can meet the needs of radar networking.
- Fast self-calibration and automatic fault diagnosis for radar equipment.
- With network communication interface.
- Multi-target tracking capability.
- **Azimuth machine scan.**
- **Two-dimensional phase scanning pulse Doppler system.**
- **Three-coordinate radar.**

Specifications

RM300 Radar	
Operating Mode	Azimuth mechanical scan, fully coherent, active 2D phased array
Operating Frequency	Ku-band
Detection Coverage	Azimuth: 360° @ mechanical scan; 90° @ electronic scan Elevation: 40° @ search; 60° @ track
Detection Range	≥5 km @ mechanical scan (search); ≥7 km @ electronic scan (search) (target RCS = 0.01 m ²)
Coverage Altitude	≥1 km
Target Speed Range	1 ~ 200 m/s
Data Update Rate	≤4 s @ search; ≤0.2 s @ track
Positioning Accuracy	Search mode: Azimuth ≤0.4°, Elevation ≤0.6°, Range ≤10 m Track mode: Azimuth ≤0.3°, Elevation ≤0.5°, Range ≤7.5 m
Target Handling Capacity	≥100 targets @ search; ≥4 targets @ track
Fault Detection Rate	≥90%
Power Supply	DC / 24V
Control Interface	Gigabit Ethernet
Power Consumption	≤400W
Physical Dimensions	Antenna Panel: 390 mm × 390 mm × 120 mm Rotator Unit: Φ216 mm × 173 mm (W × H)



RP200 Radar

Product Characteristics

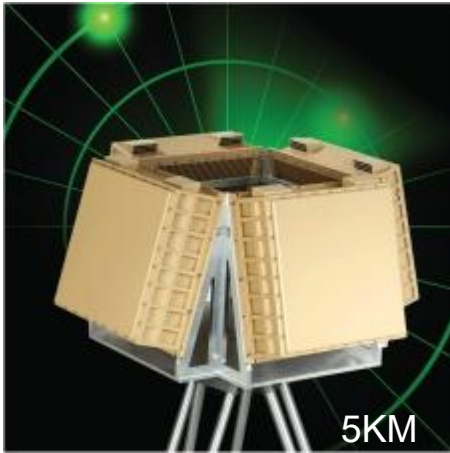

- Detection of low-speed small targets in complex background
- The interface has good compatibility and expandability, and can meet the needs of radar networking.
- Fast self-calibration and automatic fault diagnosis for radar equipment.
- With network communication interface.
- Multi-target tracking capability
- **Two-dimensional phase scanning pulse Doppler system**
- **Three-coordinate radar**

Specifications

RP200 Radar	
Operating Mode	3D solid-state, fully coherent, active 2D phased array
Operating Frequency	Ku-band
Detection Coverage	Azimuth: 360° (Quad-face configuration) Elevation: 40° @ search; 60° @ track
Detection Range	≥5 km (target RCS = 0.01 m ²)
Coverage Altitude	≥1 km
Target Speed Range	1 ~ 200 m/s
Data Update Rate	≤3 s @ search; ≤0.2 s @ track
Positioning Accuracy	Search mode: Azimuth ≤0.4°, Elevation ≤0.6°, Range ≤10 m Track mode: Azimuth ≤0.2°, Elevation ≤0.3°, Range ≤5 m
Target Handling Capacity	≥400 targets @ search; ≥16 targets @ track
Fault Detection Rate	≥90%
Power Supply	DC / 24V
Control Interface	Gigabit Ethernet
Power Consumption	≤260W per face
Physical Dimensions	Single panel: 339 mm × 347 mm × 120 mm



RP300 Radar

Product Characteristics

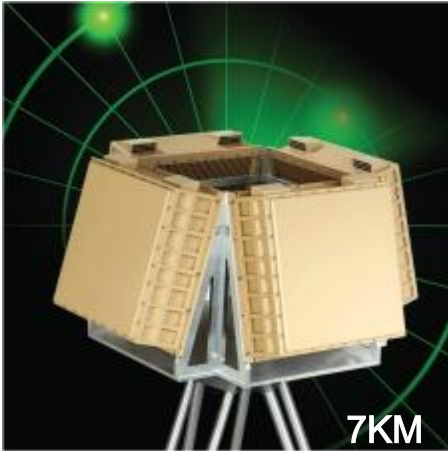

- Detection of low-speed small targets in complex background
- The interface has good compatibility and expandability, and can meet the needs of radar networking.
- Fast self-calibration and automatic fault diagnosis for radar equipment.
- With network communication interface.
- Multi-target tracking capability
- **Two-dimensional phase scanning pulse Doppler system**
- **Three-coordinate radar**

Specifications

RP300 Radar	
Operating Mode	3D solid-state, fully coherent, active 2D phased array
Operating Frequency	Ku-band
Detection Coverage	Azimuth: 360° (Quad-face configuration) Elevation: 40° @ search; 60° @ track
Detection Range	≥7 km (target RCS = 0.01 m ²)
Coverage Altitude	≥1 km
Target Speed Range	1 ~ 200 m/s
Data Update Rate	≤3 s @ search; ≤0.2 s @ track
Positioning Accuracy	Search mode: Azimuth ≤0.4°, Elevation ≤0.6°, Range ≤10 m Track mode: Azimuth ≤0.2°, Elevation ≤0.3°, Range ≤5 m
Target Handling Capacity	≥400 targets @ search; ≥16 targets @ track
Fault Detection Rate	≥90%
Power Supply	DC / 24V
Control Interface	Gigabit Ethernet
Power Consumption	≤325W per face
Physical Dimensions	Single panel: 390 mm × 390 mm × 120 mm